

M05

Handheld 3D Laser Scanning System

User Manual

Statement

Copyright

The copyright of this manual belongs to Wuhan Eleph-Print Tech Co., Ltd. and all rights are reserved. Without written permission, any company or individual shall not disclose, reproduce or otherwise distribute any part of this document to a third party. Otherwise, they will bear legal responsibility

Trademark

Eleph-Print Technology is a registered trademark of Wuhan Eleph-Print Tech Co., Ltd. and all other product or trademark names mentioned in the manual are the property of their respective companies.

Equipment Maintenance

Please do not try to disassemble the hardware equipment by yourself, you may get electric shock or damage the equipment. For all the maintenance request, please contact the technician of Wuhan Eleph-Print Technology Co. Ltd.

User Support

If the performance, product structure, installation method and usage precautions of the equipment change, users should contact Wuhan Eleph-Print Technology Co., Ltd. to get the latest manual.

Preface

This manual is applied to users using 3D laser scanning technologies and the users are required to have knowledge relating to:

- Conventional Surveying
- 3D laser measurement



Warning: Pls read this user manual carefully before operating M05 in case of wrong operation .

Catalog

1. General Introduction	4
1.1. Product Introduction	4
1.2. Main Technical Specification	5
2. Hardware	6
2.1. Mainframe	6
2.2. Battery	6
Power On	7
Power Off	7
3. Installation & Disassembly	7
3.1. Preparation Before Installation	7
3.2. Installation & Disassembly	8
Installation of Handle Battery	9
Disassembly of the Handle Battery	9
4. Device Operation	10
4.1. Power On	10
4.2. Camera Operation	10
4.3. Mainframe Connection	11
4.4. Device Shutdown	12
4.5. Battery Charging	12
5. 5.Data Collection	13
5.1. Field Software Installation	13
5.2. Software Start Up	15
5.3. Field Software Interface	15
5.4. Parameters Settings	16
5.5. Data Collection	17
Scanning Route Planning	18
Scanning Method	18
Precaution During the Data Collection	19
6. Data Processing	20
6.1. Data Copy	20
6.2. 6.2 Software Installation	20
Software Installation Environment	20
EPICloud Center Viewer Installation	20

Installation of the USB Dongle Driver	21
6.3. Data Resolution	22
Data Importation	22
Automatic Resolution	23
Colorization(with image data)	25
Manual Alignment (with image data)	26
6.4. Coordinates Conversion and Data Export	29
Coordinates Format	29
Coordinates Conversion	29
Coordinates Conversion and Point Cloud Export	30
7. Appendix	31
7.1. Common Trouble Shooting	31
7.2. Precautions for the use of equipment	31

1. General Introduction

1.1. Product Introduction

M05 is a portable 3D laser measurement system independently developed by Wuhan Eleph-Print Technology Co., Ltd. with the design concept of lightweight, use-friendly, integration of high-precision LiDAR sensor, image acquisition and other technologies. M05 Laser Measuring System is a laser measurement system that can be used to scan and acquire 3D data in a simple and efficient way.

The main applications of M05 include, but not limited to, house elevation measurement, accident scene investigation, stocking pile volume calculation, interior decoration, digital park and other fields.

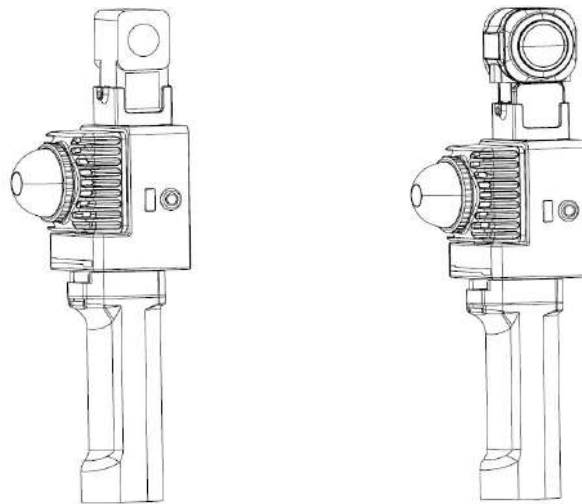

Figure 1-1 M05 Handheld 3D laser scanner

1.2. Main Technical Specification

The main technical specification of M05 handheld 3D laser scan is as below,

Chart 1-1 **M05 Main Technical Specification**

System Specs	Weight	930g
	Operating Temp.	-10°C - 50°C
	Storage Temp.	-20°C - 60°C
	System Consumption	20W (Typical)
	Power Supply	12V - 17.6V
	Battery Life	1.5h
	Storage	USB flash 64GB
	Platform	Handheld
	Type of Charging	Type-C
LiDAR Unit	Scanning Range	<u>0.1m ~ 70m@80% Reflectivity</u>
	Laser Class	Class 1
	FoV	Horizontal 360°, Vertical -7° - 52°
	Length of Laser	905nm
	Scanning Rate	200,000pts/s
	Relative Accuracy	2cm
	Absolute Accuracy	5cm
Camera Unit	FoV	360° Panoramic camera
	Resolution	18MP

2. Hardware

M05 has 2 editions according to the different camera.

The basic edition includes mainframe,battery,USB flash and Insta ONE RS dual camera,etc.

The pro edition includes mainframe,USB flash and Insta ONE RS one inch camera,etc.

2.1. Mainframe

M05 mainframe and interfaces as pic. 2-1 below,

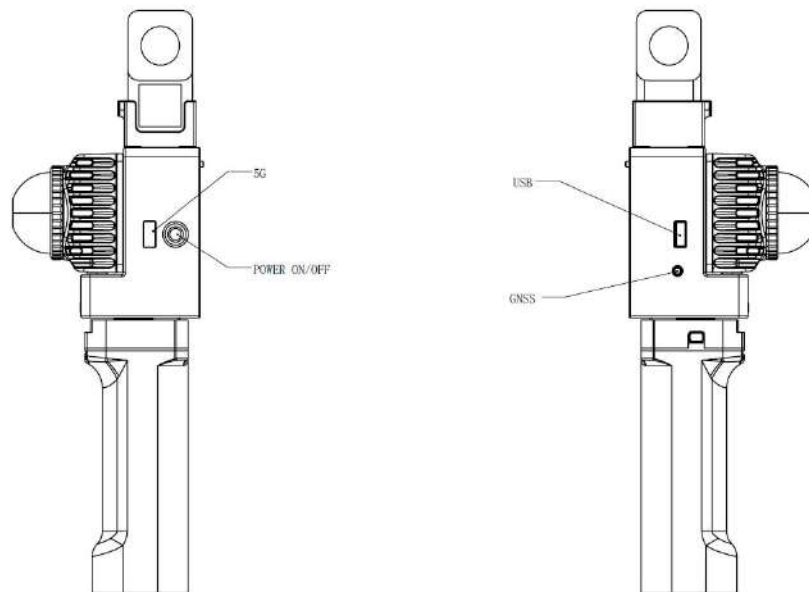

Figure 2-1 M05 mainframe and interfaces

2.2. Battery

M05 is powered by a handle battery as pic. 2-2 below,

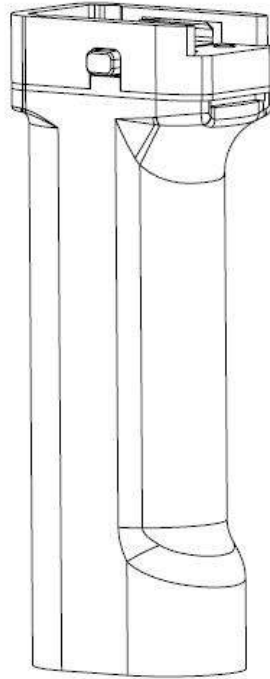

Figure 2-2 M05 Battery



Warning:

1. It is prohibited to immerse the battery in liquid (e.g. water, seawater, etc.), and the battery should be placed in a cool and dry environment when not in use;
2. It is prohibited to place the battery to be close to high temperature sources (e.g. fire, heaters, etc.);
3. It is prohibited to knock, press, throw or step on the battery.
4. Do not continue to use the battery if it is inflated.
5. The battery is equipped with a specialized charger, please do not replace it with other models of charger.

Power On

In the battery off state, firstly short press the handle battery button 1 time, the power indicator is green, then long press the power button on the mainframe for more than 3 seconds to turn on the device. When the battery is on, the power indicator light is green and the green light flashes to show the current battery level.

Power Off

In the battery on state, long press the device power button for more than 3 seconds, the device indicator light is off then the device shutdown is successful.

3. Installation & Disassembly

3.1. Preparation Before Installation

Before installation of M05, pls check if the item list is complete.

Item List for basic edition

	No.	Items	Unit	Qty.
Device	1	M05 Mainframe	PCS	1
	2	Handle battery	PCS	1
	3	Insta 360 ONE RS dual cameras	PCS	1
Others	1	USB Dongle	PCS	1
	2	《M05 User Manual》	PCS	1
	3	《M05 Item List》	PCS	1
	4	《Quality Certificate》	PCS	1
	5	《Warranty Card》	PCS	1

Item List for Pro edition

	No.	Item	Unit	Qty.
Device	1	M05 Mainframe	PCS	1
	2	Handle battery	PCS	1
	3	Insta 360 ONE RS one inch camera	PCS	1
Others	1	USB Dongle	PCS	1
	2	《M05 User Manual》	PCS	1
	3	《M05 Item List》	PCS	1
	4	《Quality Certificate》	PCS	1
	5	《Warranty Card》	PCS	1



Note:

The above list is just an example. Please refer to the packing list that comes with the equipment.

3.2. Installation & Disassembly



Warning:

1. When installing the M05, please hold it gently to protect the equipment;

2. When installing or dismantling the handle battery, make sure that the battery is turned off to avoid damage to the device from energized operation;
3. After disassembling the equipment, please put the parts of the equipment back into the carry case properly.

Installation of Handle Battery

Follow the direction of the arrow shown in the picture below to connect the handle battery to the mainframe and gently push it inward to the bottom.

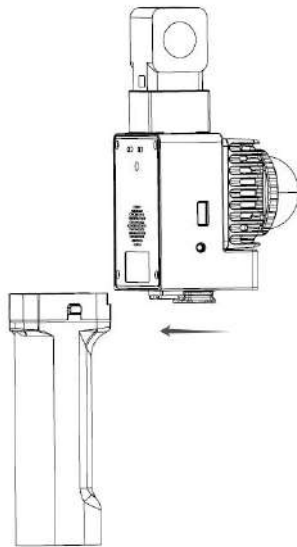

Pic. 3-1 Installation of Handle Battery



Warning:

1. The handle battery used for M05 has a mounting direction, so please pay attention to the mounting direction of the battery when installing it;
2. Please be gentle when installing the handle battery to avoid excessive force that may cause damage to the device.

Disassembly of the Handle Battery

Ensure that the battery and the mainframe are powered off, push off the press-fastener, and separate the handle battery from the mainframe in the direction of the arrows.

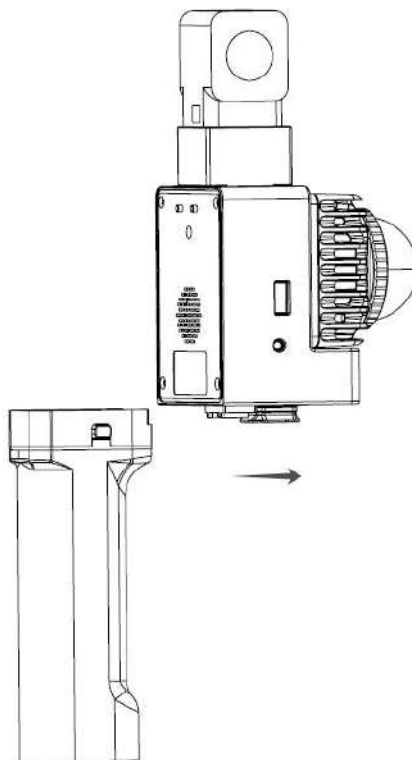

Figure 3-2 Disassembly of Battery

4. Device Operation

4.1. Power On

1. After completing the installation of the device in accordance with the steps described in section 3.2.1, you can start using the M05 system.
2. Press the M05 handle battery power on/off button.
3. Within 3 seconds, long press the M05 mainframe power button for more than 3 seconds, its indicator light will come on and the unit will start up.
4. After the indicator light is on, you can use your Android smart phone or tablet to search for WiFi hotspots, and when the WiFi access point named "M05" is found, the system will start normally.



Note:

It will take less than 1min to do initialization, keep patient while waiting for it.

4.2. Camera Operation

M05 is equipped with Insta360 ONE RS series camera, pls refer to Insta360 ONE RS user manual or ask for the guidance from EPiC's technician.

4.3. Mainframe Connection

The M05 supports a wireless connection.

1. Use your Android smart phone or tablet to search for a WiFi hotspot and find the WiFi access point named "M05";
2. Use the password "12345678" to join the "M05" hotspot, and set the WiFi IP acquisition method to obtain IP automatically.



Note:

1. IP for M05 is 92.168.12.1;

4.4. Device Shutdown

1. After the system stops collecting data and data transmission is complete, pls click on the "shutdown" button to shut down the device, as shown in Figure 4-4;



Figure 4-1 Device Shutdown

2. The shutdown of the device can be completed when the M05 mainframe status indicator goes off.



Warning:

- 1、 Please do not disconnect the battery directly when the mainframe is not completely shutdown to prevent damage to the device.
- 2、 When the device is shut down and needs to be packed and transported, please remove the handle battery from the device and place it properly in the carry case.

4.5. Battery Charging

Charging Port: Type-C

Charging Power Voltage/Current: 5V/2A, 9V/2A, 12V/2A, 5V/1.6A



Note:

1. If the battery is not used for more than 10 days, please

discharge the battery to about 50% of its capacity for storage.
2. If the battery is left unused for a long period of time, it should be recharged and discharged every 3 months or so to keep the battery in good condition.

5. 5.Data Collection

5.1. Field Software Installation

Insert the USB flash included with the product on the PC and copy the Easy Point Access M05 xxx.apk installer to the PC. Copy the installer to the download folder on your phone via the USB cable.

Access the download folder on your phone, select and click install.

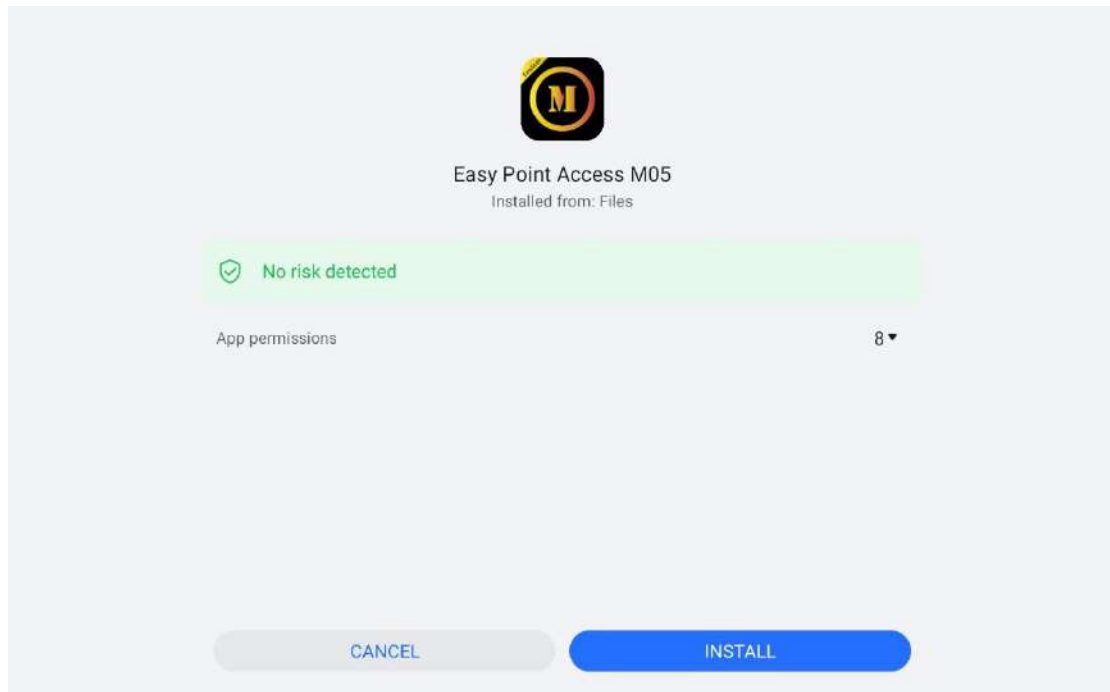

Figure 5-1 Field Software Installation

In the pop-up permission dialog box to authorize the software required permissions, if not authorized, some of the software functions can not be used.

Click continue to install and wait for the software to finish installing.

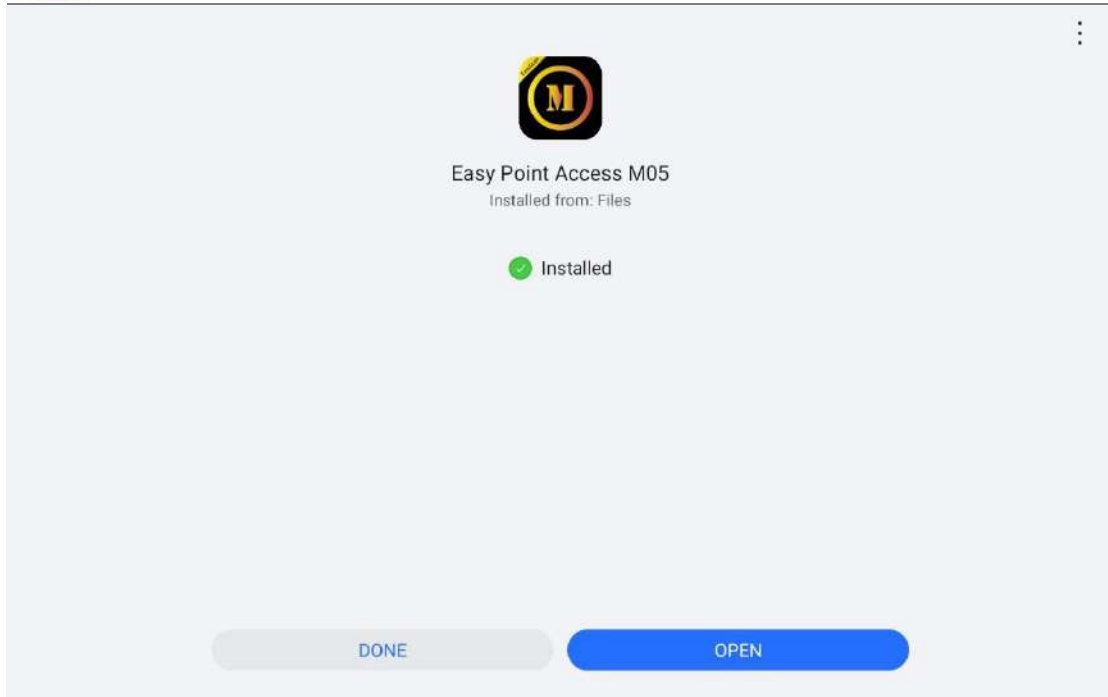
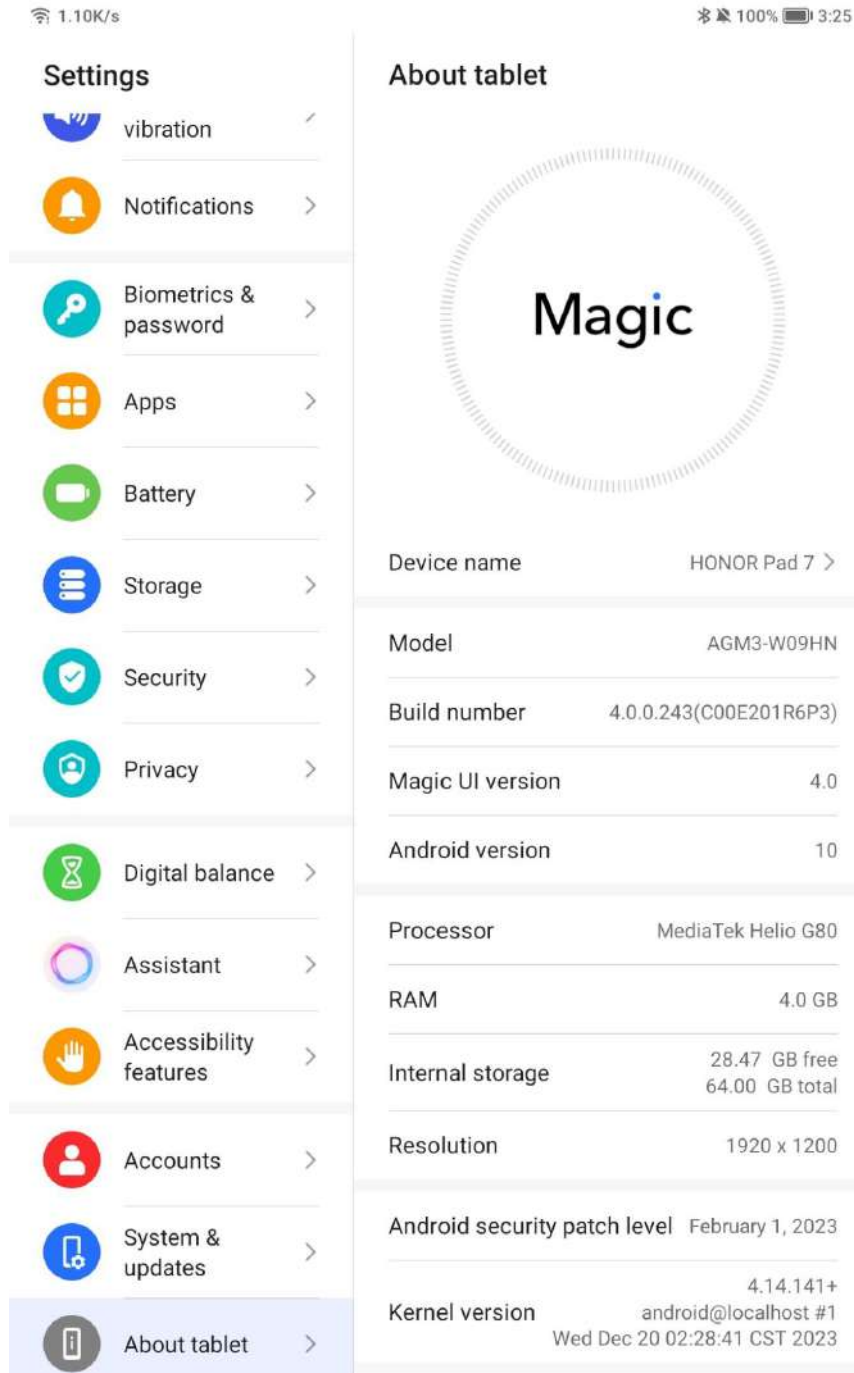

Figure 5-2 Field Software Installation

Note:Its recommended to use Android 10、 11、 12 and Harmony OS 3.0 as example shown below,

- 1、 Tablet PC: HONOR 7



5.2. Software Start Up

Power on M05 and wait for 30S, connect the WIFI hotspot with the name of M05-XXXX(XXXX is the device serial number);

The initial WIFI password is: 12345678;

Open the app installed on the Android device.

5.3. Field Software Interface



Figure 5-3 Software Interface

- ① Settings, click it to enter the setting interface.
- ② Device connection status display, showing the device connection status.
- ③ The remaining storage of USB flash is displayed.
- ④ Camera connection status display, showing the camera connection status.
- ⑤ Satellite signal status display.
- ⑥ Point cloud collection status display, the animation effect during the acquisition process indicates that the acquisition is in progress.
- ⑦ Device temperature display, monitoring the temperature of the device.
- ⑧ All data growth in the process of data acquisition.
- ⑨ Start Acquisition button, click on the start acquisition button, the device begins to collect point cloud.
- ⑩ Mark point button, click the button to mark point.
- ⑪ Locking the following view of real-time point cloud, as well as unlocking the following view.
- ⑫ Adjust to top view of the real-time point cloud.
- ⑬ Adjust to the side view of the real-time point cloud.
- ⑭ Adjust to front view the real-time point cloud.
- ⑮ Device shutdown button, click it to shut down the device.

5.4. Parameters Settings

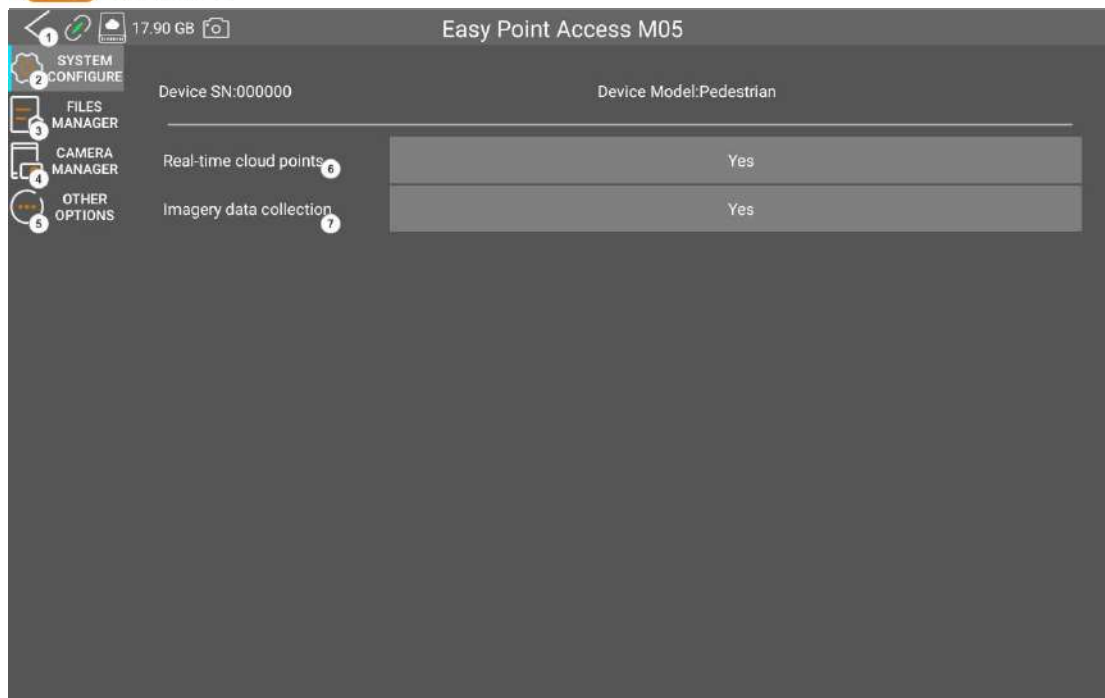

- ① Exit the parameter setting interface and return to the control acquisition interface.
- ② Configure the scanner.
- ③ Manage the collected data files, checking the data completeness and deleting them.
- ④ Manage the image files and download them.
- ⑤ Export the log of the acquisition process, which is convenient to find a certain situation in the process.
- ⑥ Real-time point cloud switch, its on by default, if it is changed to off, real-time point cloud will not appear in the acquisition process.
- ⑦ Capture image switch, its on by default, if changed to off, no image will be captured during the acquisition process.

5.5. Data Collection

① Power on the device and camera, use the Android handheld device to connect the M05 via WIFI, open the software, enter the setup interface to adjust the settings, and then return to the control interface, click on Start Acquisition icon, waiting for 5 seconds or so, M05 starts collecting data, the upper left side of the control interface will begin to record the collection of data, at the end of the data acquisition, click on the stop collection icon, it will begin to download the image data, when the countdown is finished (if the camera download failed, please download the image file in the camera management interface), the data collection is done. All the data will be saved to the specified folder in the USB flash disk.

- ② When all projects of data have been collected, unplug the USB flash drive and copy the collected data to PC, and then use the post-processing software to resolve the data.

Scanning Route Planning

- ① Make a good route planning before the scanning job, try to make the route a closure loop as possible (do not have to be closure loop, it is just better to have a closure loop).
- ② Ensure that the collection is carried out according to the planned route, and try to scan the scene completely.
- ③ The scanning route should be as smooth as possible to avoid duplicate scanning to add workload.
- ④ Try to avoid moving objects as much as possible (don't scan at the time when there are many people and cars), or deal with the factors that may affect the collection in advance, such as removing the clutter that affects the normal walking, and opening the door in advance that you have to pass through.
- ⑤ When walking around the corner of a building, turn the lidar slightly to align it with the building (tilt the device slightly toward the building when making a turning).
- ⑥ When encountering more complicated scenes or areas that need

to be scanned particularly, the walking speed should be slowed down appropriately and the scanning duration can be increased.

Example: If we want to scan the data of two buildings, we should collect the data as the route planned in the figure as below, starting and ending at the middle of the two buildings to make a closure loop route. Increasing the closure loop has a constraint effect on the overall scale of the point cloud, which can suppress the cumulative error of the slam construction caused by time.

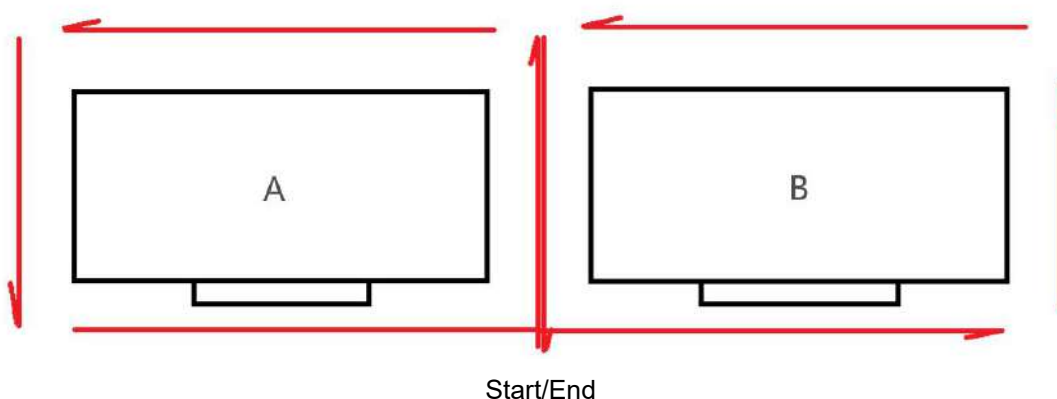

Scanning Method

- ① Horizontal scanning: can be used in most scenes, the camera colorization is under horizontal scanning mode by default, no need to adjust when do colorization.

- ② Vertical scanning: can support long distance of scanning, but less quality for large scene of data, due to the accumulated errors, it will lead to the overall point cloud deformation, bending and camera colorization needs to be adjusted in the post-processing software.



Data from horizontal scanning of a tunnel



Data from vertical scanning of a tunnel

Precaution During the Data Collection

1. Prohibition of work in extreme weather conditions such as rain or snow

- ③ Before collecting data, you should check the battery level, if the battery is too low, it should be fully charged before starting the operation.
- ④ The battery can support 2.5 hours of continuous collection, please arrange the operation duration reasonably.
- ⑤ When it encountered special circumstances during the collection process, the user can avoid or stop collection appropriately.
- ⑥ The equipment shall be kept stationary during the process of starting and stopping acquisition.
- ⑦ The horizontal scanning range of the device is 360° , and the vertical scanning range is $7\sim 52^{\circ}$ (the default acquisition mode is horizontal scanning), and the accompanying personnel should follow behind the acquisition personnel during the whole job.
- ⑧ Taking normal walking speed during the collection process.
- ⑨ When encountering special scenes or more complex scenes, the scanning time can be increased appropriately.
- ⑩ Turn slowly around corners and do not turn too sharply.
- ⑪ If scanning distance is very long, it's needed to slow down.
- ⑫ When there is a change of scene, e.g. from indoors to outdoors, you should slow down when approaching the door and then turn sideways to go out.
- ⑬ To mark the control point, place the alignment point of the base plate against the control point, click on the marker on the software, keeping it standing for about 10S, then pick up the device and continue walking to scan.

6. Data Processing

6.1. Data Copy

Remove the USB flash drive from the device, plug it into the PC, open the USB flash drive, the name of the folder is the date of the collection data, each folder contains an image data folder, a raw point cloud folder, a POS data folder and a Json file, copy the data that needs to be processed to the PC.



Figure 6-1

6.2. 6.2 Software Installation

Software Installation Environment

Recommended configuration of PC:

Processor	11th Gen Intel(R) Core(TM) i7-11800H @ 2.30GHz 2.30 GHz
Installed RAM	32.0 GB (31.8 GB usable)
Device ID	75F7B10F-5BF1-4347-99E9-53865C373CBB
Product ID	00329-10458-00000-AA393
System type	64-bit operating system, x64-based processor
Pen and touch	No pen or touch input is available for this display

Figure 6-2 PC configuration

EPiCloud Center Viewer Installation

EPiCloud Center Viewer is the post-processing software for slam devices, this software is free installation mode.

Open the unzipped folder, select from [Type-Application], EPiCloudCenterViewer.exe is the post-processing software, send the shortcut of the software to the desktop for future use.

名称	修改日期	类型	大小
temp_dll	2023/11/2 10:57	文件夹	
styles	2024/1/16 14:03	文件夹	
plugin	2024/1/16 14:03	文件夹	
platforms	2024/1/16 14:03	文件夹	
imageformats	2024/1/16 14:03	文件夹	
iconengines	2024/1/16 14:03	文件夹	
gdal_data	2024/1/16 14:03	文件夹	
ffmpeg	2024/1/16 14:03	文件夹	
data	2024/1/16 14:03	文件夹	
configs	2024/1/16 14:03	文件夹	
zlibwapi.dll	2023/7/6 15:35	应用程序扩展	102 KB
zlib1.dll	2022/6/20 8:07	应用程序扩展	84 KB
xerces-c_3_1.dll	2022/6/20 8:07	应用程序扩展	2,472 KB
wpcap.dll	2022/6/27 14:02	应用程序扩展	362 KB

Figure 6-3

名称	修改日期	类型	大小
testProjection.exe	2024/1/3 13:29	应用程序	26 KB
ImuCalib.exe	2023/9/25 10:04	应用程序	1,576 KB
EPICloudCenterViewer.exe	2023/12/28 14:01	应用程序	10,843 KB
EPGetKey.exe	2023/7/25 12:34	应用程序	132 KB

Figure 6-4 Post-processing software

Installation of the USB Dongle Driver

Get the installation folder sense_shield_installer_pub in the USB flash driver and double click it, then install it following the given step.



Figure 6-5 USB dongle driver installation

After the installation is complete, insert the blue USB flash dongle into the PC, open the

EPiCloudCenterViewer, if the software can be opened normally, and it contains the Slam plug-in module, then it means the software installation is successful.

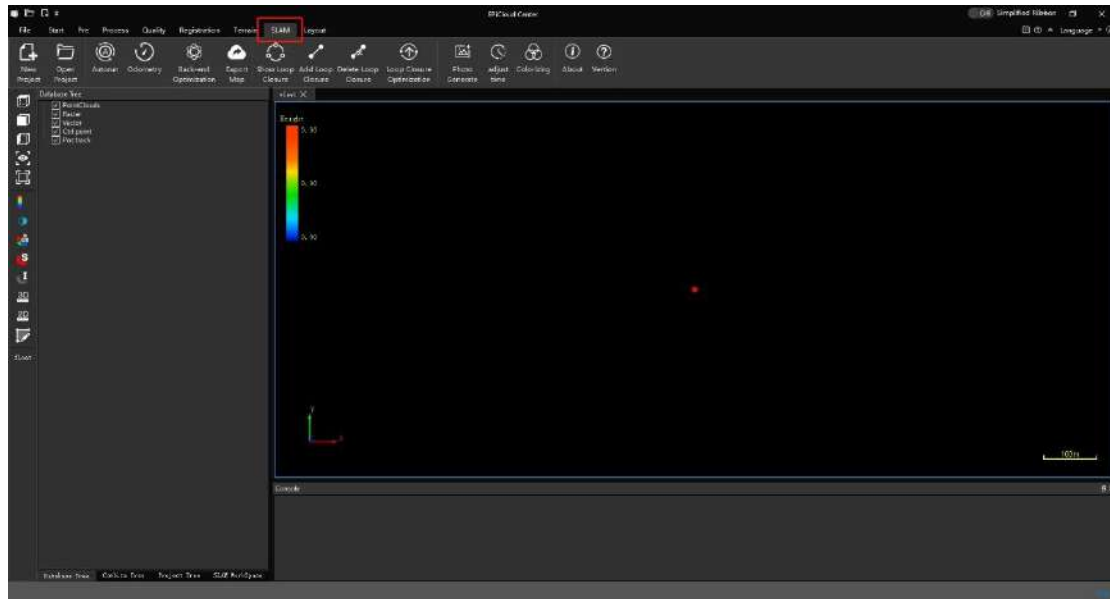

Figure 6-6 SLAM Plug-in Module

6.3. Data Resolution

Data Importation

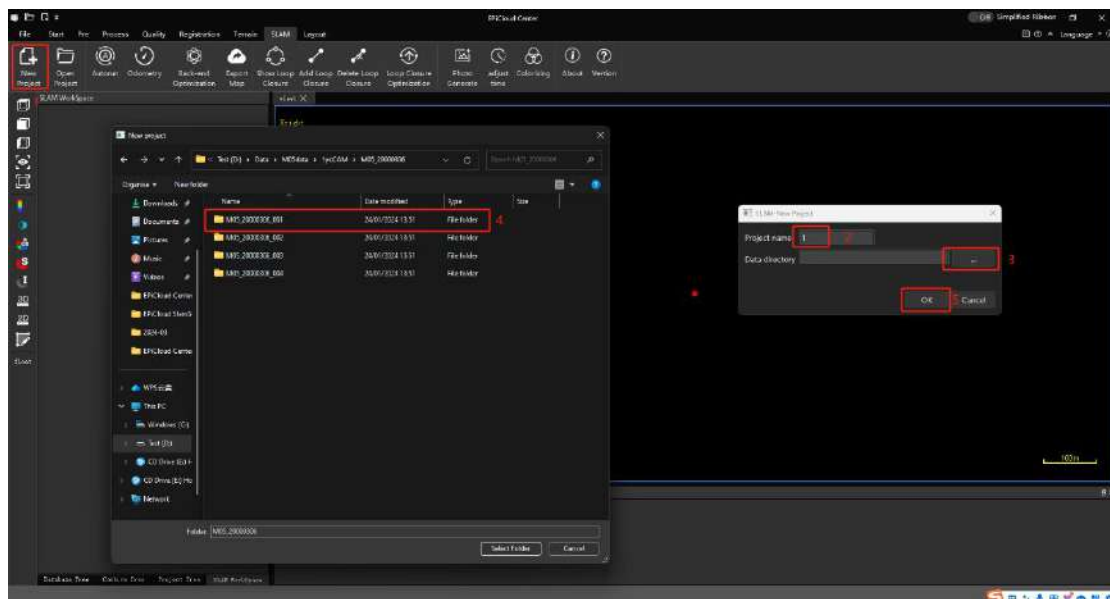

Figure 6-7 Data Importation

- ① Click "New Project" in the Slam module to bring up the "New Project" window.
- ② Enter the project name(letter+number)
- ③ Click "data catalog" to get "folder window"
- ④ Select the data group to be imported (select the subsidiary folder of the data group folder).

⑤ Click "confirmation"

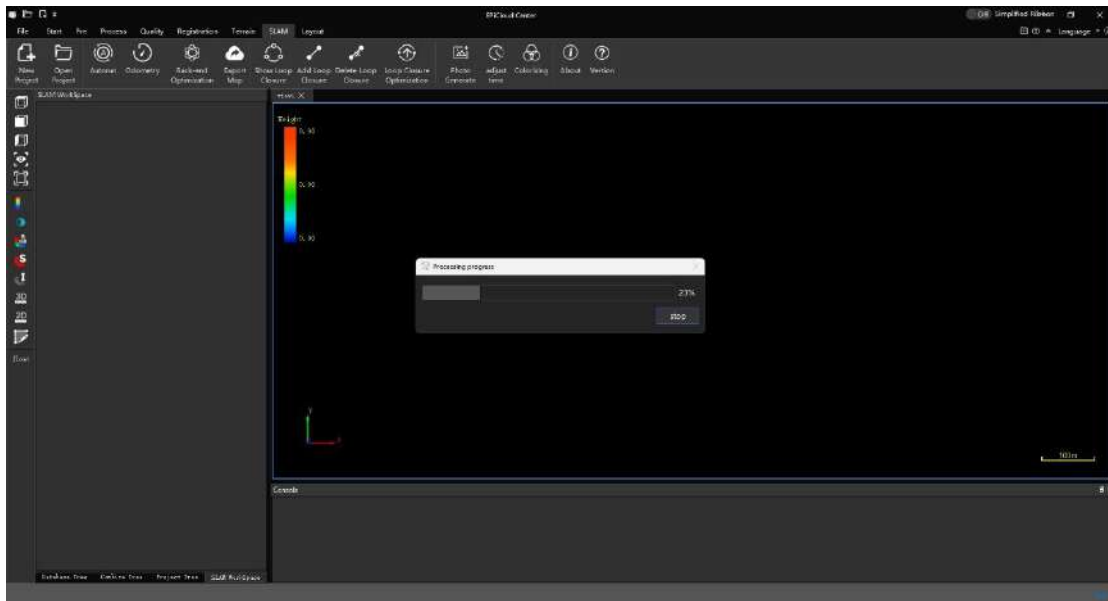

Figure 6-8 Data Importation

Automatic Resolution

Click auto running and select new SLAM algorithm

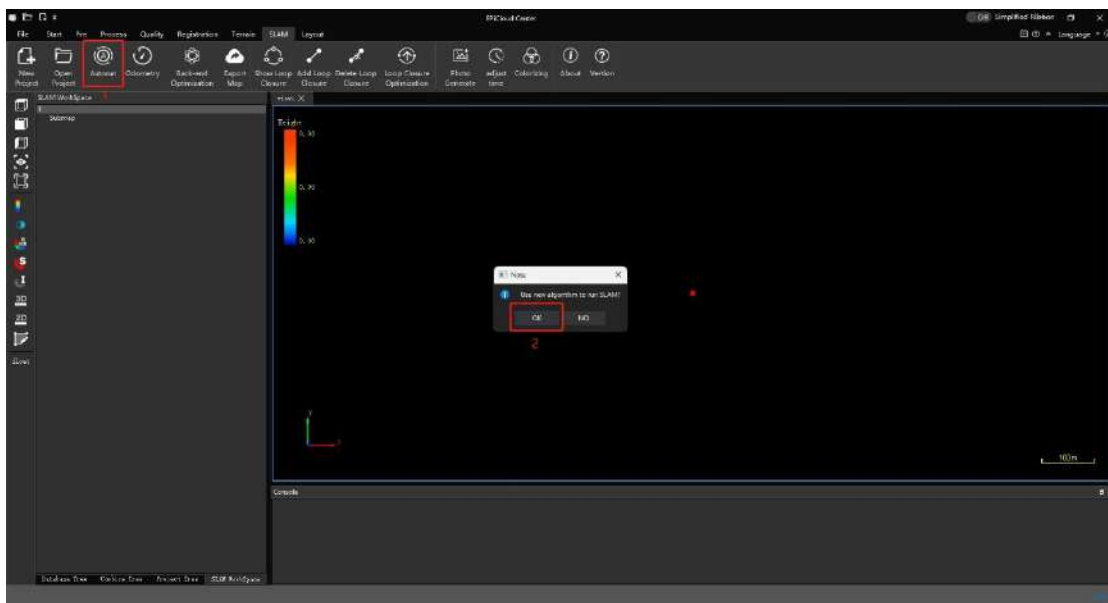

Figure 6-9 SLAM algorithm selection

Select the appropriate scene and parameters in the pop-up window, and use the default values for the rest of the parameters.

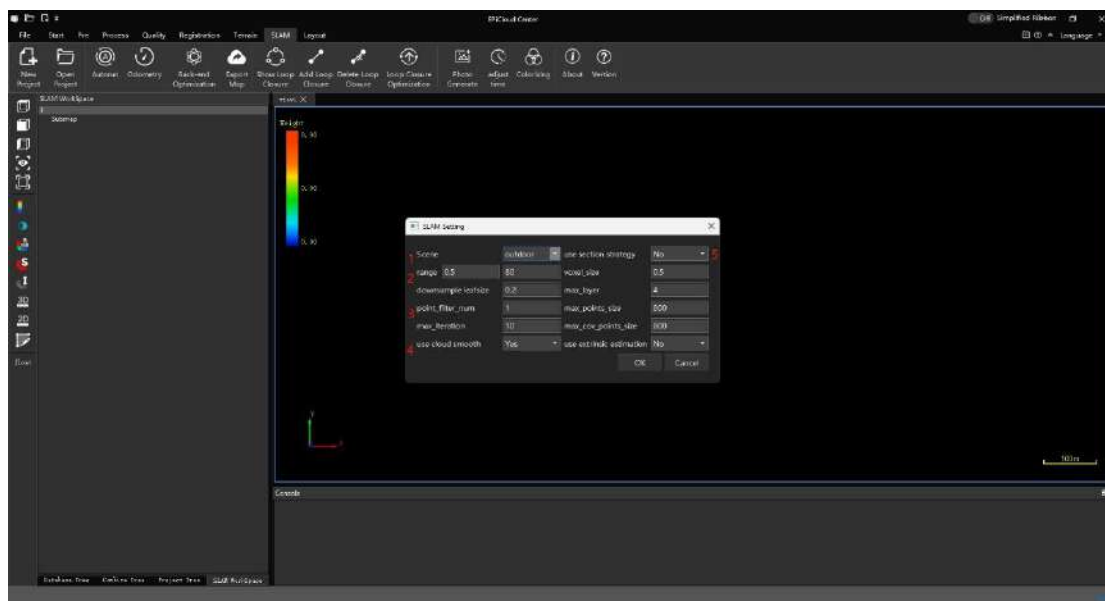

Figure 6-10 Parameters Selection

- ① Scenario selection: according to the actual data collection scenario, select the corresponding option.
- ② Effective point range: the unit is "meters", keep the points within the range and remove the points outside the range.
- ③ Filtering point interval: thinning the point cloud, the minimum value is "1" and the point density is maximum correspondingly, data processing time is longer, the point cloud effect is better.
- ④ Use point cloud smoothing: Smooth and optimize the point cloud. Selecting "yes" will increase some processing time.
- ⑤ Use segmented mapping strategy: Select "yes", the processed point cloud will be divided into multiple sub-images, which can be manually optimized; select "No", the generated point cloud will be a whole point cloud map, it is recommended to choose not to segment .

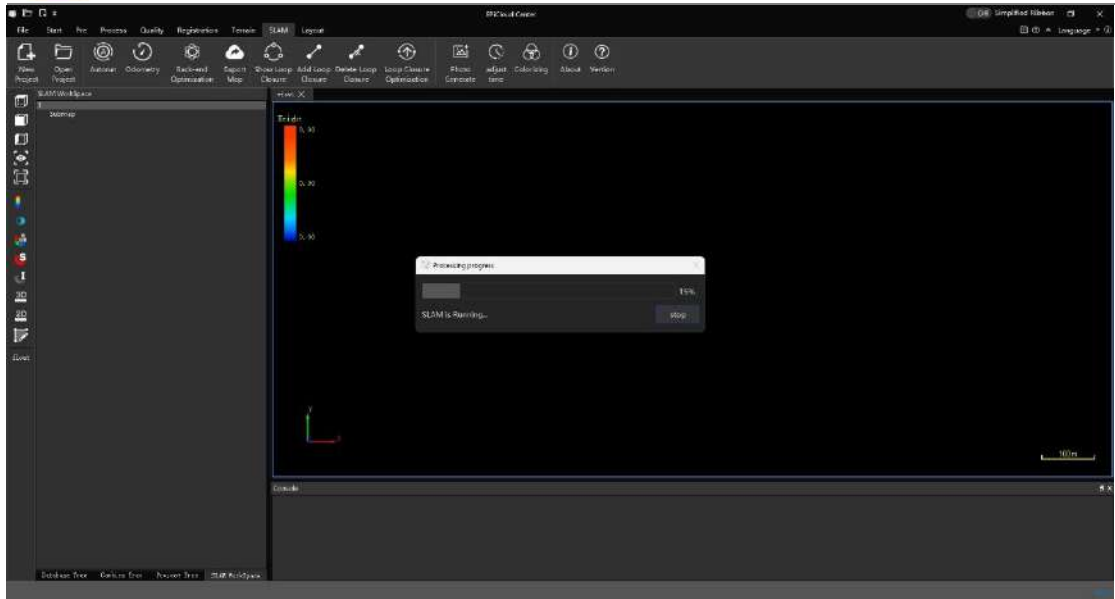

Figure 6-11 Auto Resolution

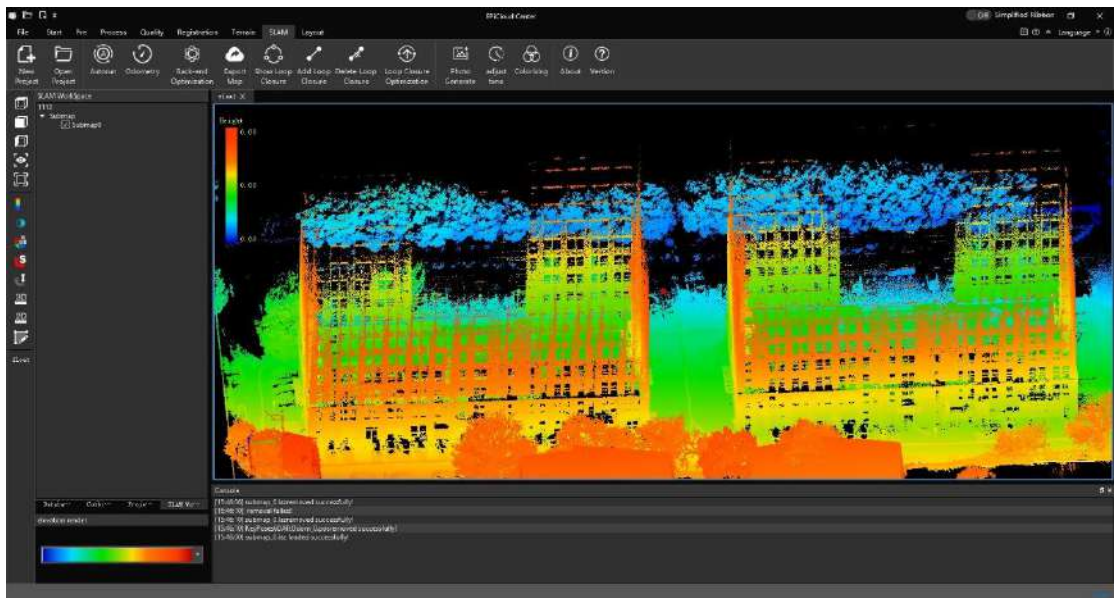

Figure 6-12 Point Cloud Display

Colorization(with image data)

Click image generation to automatically generate photo from the collected video stream files.

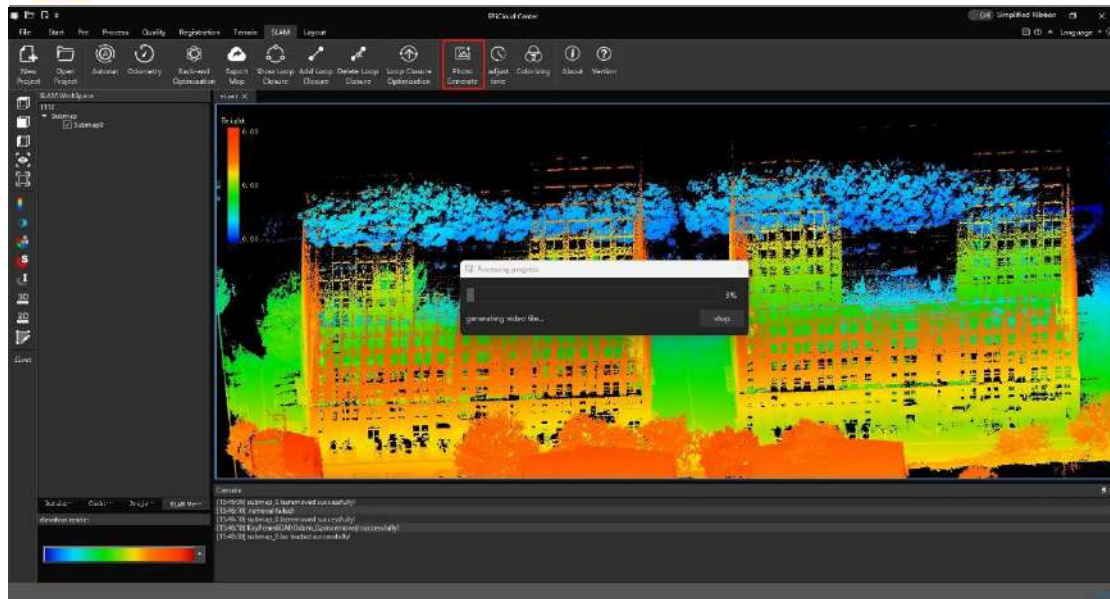

Figure 6-13 Generation of Colored Image

Click "colorization" to generate colored cloud point.

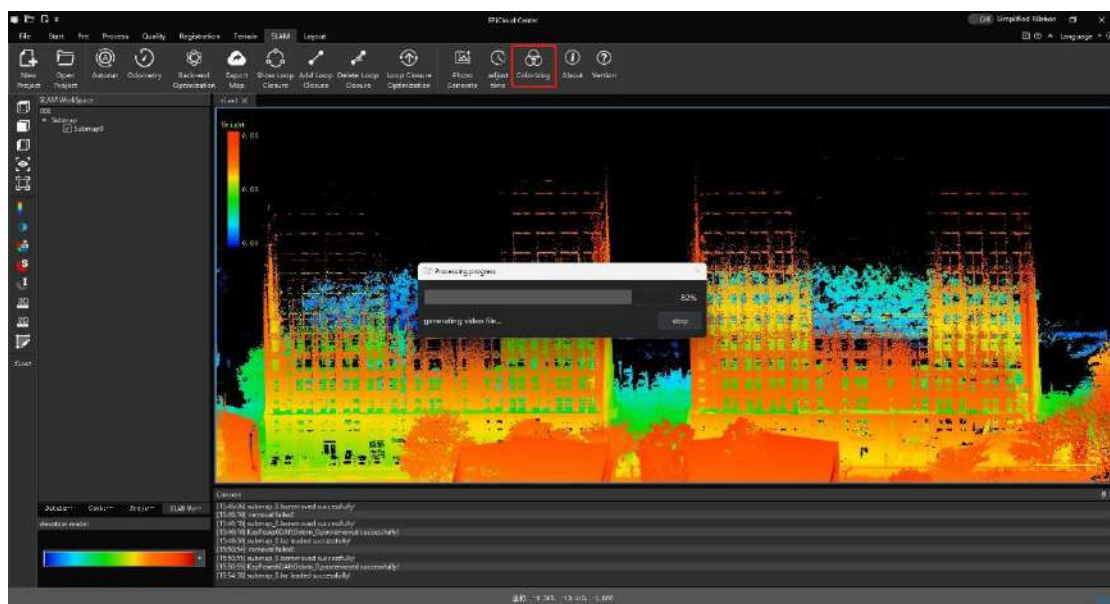

Figure 6-14 Generation of Colored Cloud Point

Manual Alignment (with image data)

If the automatic color assignment does not meet the requirements, time adjustment and alignment are required.

① Why do we need to adjust the time?

Because the time systems of lidar and camera are two different systems, hard synchronization is not possible, and the time of the two cannot be automatically matched. There will be a time deviation in each acquisition. Therefore, when we process this type of laser point cloud and photo data, it is necessary to constrain the first frame time and register it to achieve the effect of overlapping the point cloud and the image and ensure the accuracy of color assignment.

② What is the logic for time adjustment?

First of all, M series product images adopt delayed photography mode. In actual processing, photos are selected according to a certain time period, so that each photo can be set as a reference point, and each reference point can be matched with the image and point cloud. Many The reference point connection is the image trajectory. The process of adjusting the time difference is the process of correcting the starting point of the image. The implementation logic is: ensure that the point cloud position remains unchanged, and the image trajectory is adjusted according to the time difference.

For example: the default position is 1-2-3-4, adjust the time, and after adjusting the difference, the position will change, as shown below:

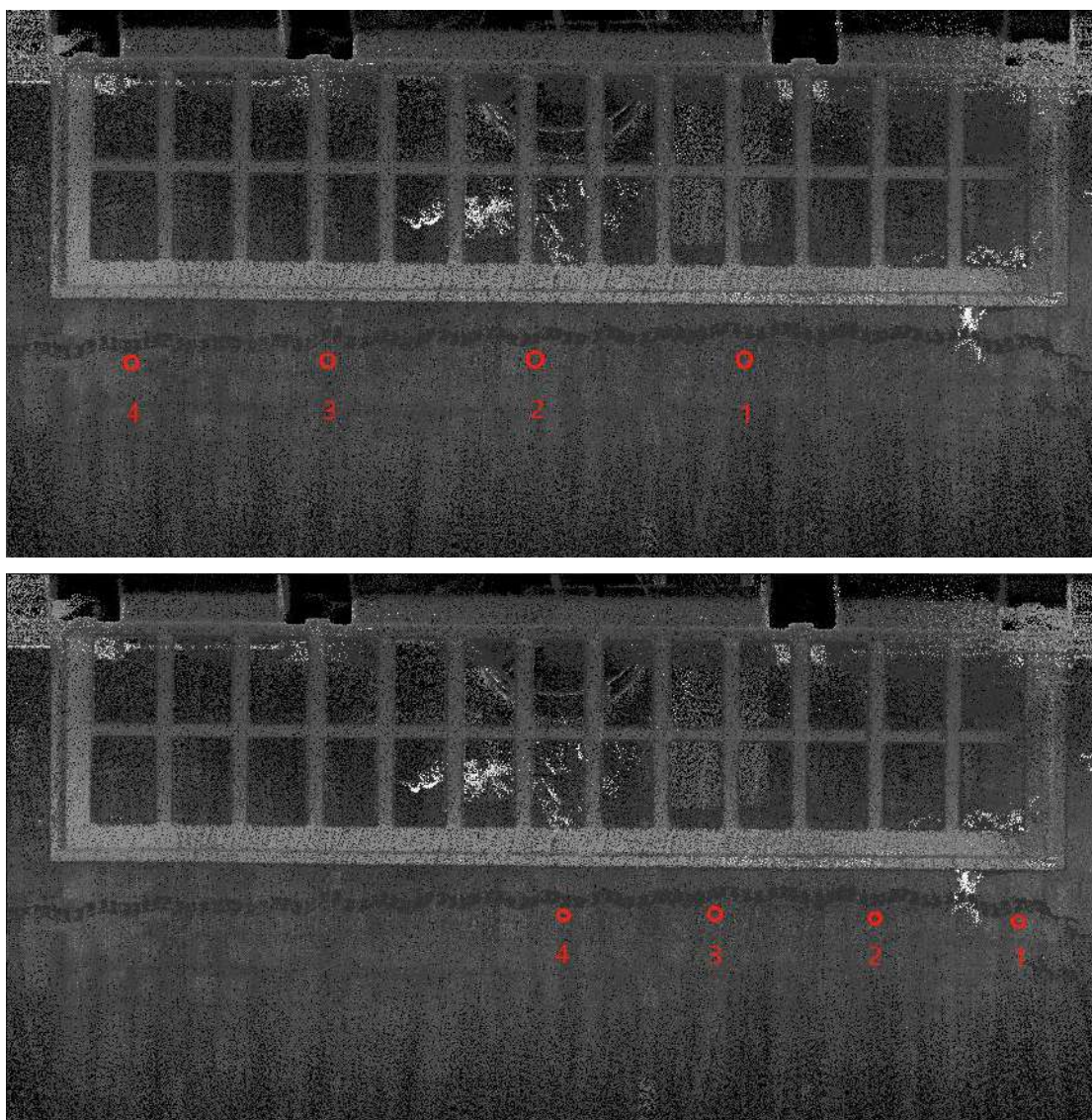

① How to adjust quickly and easily?

First of all, we need to solve the data for both, solve the original point cloud and image into the format we need; after displaying the point cloud, click the "Time Adjustment" icon, a dialog box will pop up, the default is the first frame of the image, the value of time difference is 0, click the

Update button, the view will be defaulted to the first frame of the first photo in the first-person perspective. You can see the match between the point cloud and the panoramic image; at this time, it is recommended to set the point cloud to Intensity Rendering Mode in the "Display" column, so that you can see the match between the point cloud and the image more clearly; as shown in the figure below:

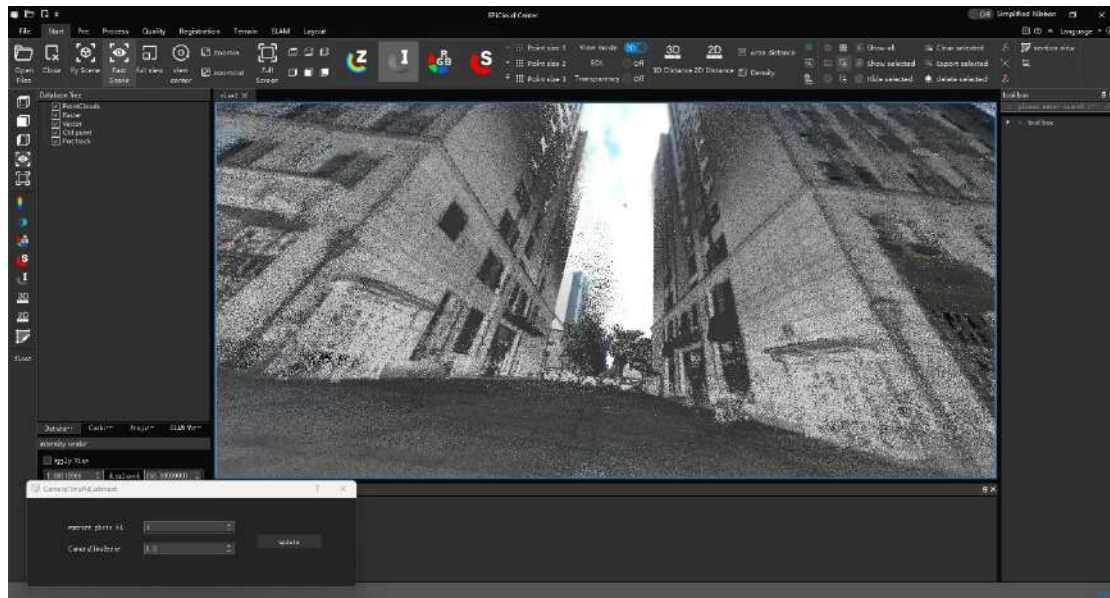

From the figure roughly view, the image and point cloud match is not bad, but does not mean that the adjustment has been completed, we need to zoom in on the view, to see the elevation of the lower and closer to the match, as shown in the figure:

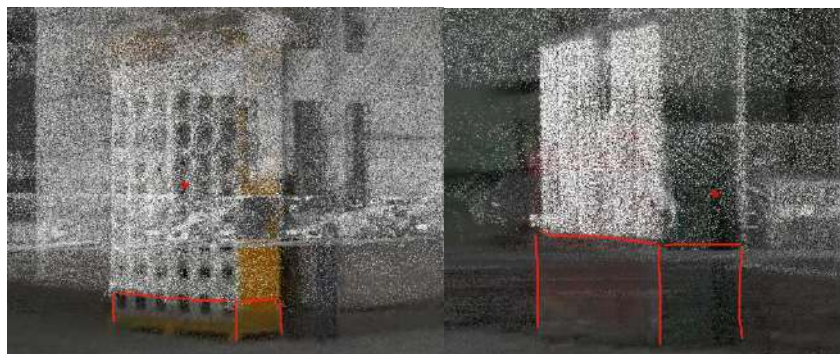

So we can see that there is an obvious deviation. So, here we can first use the following parameters to adjust. M10 device time difference can use the default of 0; M05 device time difference can be set to -3.3. Since the first frame position may have some error, we can choose the second frame or the back of the frame position to adjust. You can refer to the figure as shown:

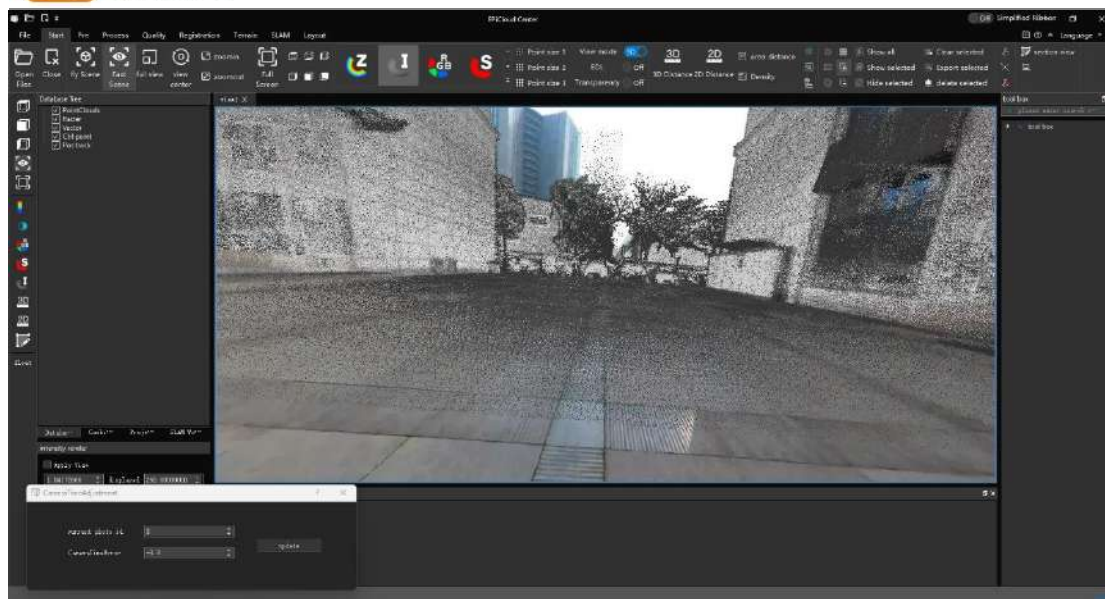

After adjustment, click Update to confirm, and then click the "Point cloud color" button and wait.

6.4. Coordinates Conversion and Data Export

Coordinates Format

Save the collected control point coordinates as a TXT file in the format of North East, Height, shown as below,

```

1 422100.6459 4456212.7836 108.854
2 422091.5565 4456239.1971 109.189
3 422071.9323 4456259.1672 109.661
4 422056.0283 4456284.9847 109.959
5 422030.3400 4456278.1426 109.478
6 421998.3166 4456259.4834 108.516
7 421966.2125 4456241.2693 107.51
8 421972.5840 4456215.4390 106.514
9 422054.8047 4456092.3197 105.379
    
```

Figure 6-15 Coordinates Format

When saving the coordinates, pls note the following:

Coordinates Conversion

- It should be saved as .txt format.
- The control points must be consistent with the quantity and order of the marked points.

Control point coordinates should be saved in the format of north,east,height as sample shown

below,

Coordinates Conversion and Point Cloud Export

Click [Export Map] in the slam module to bring up the point cloud export window.

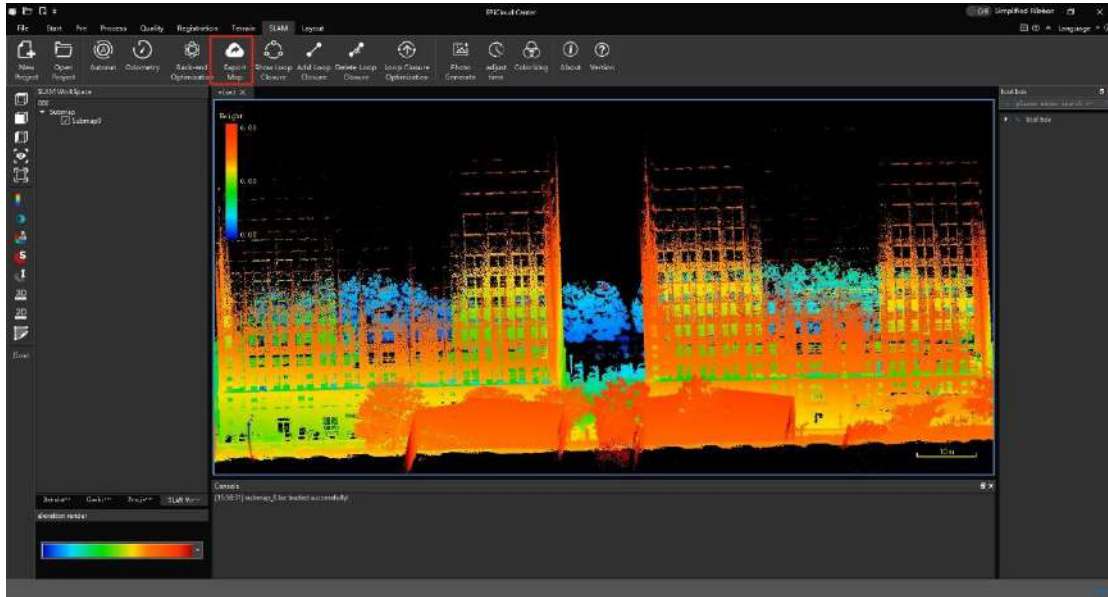

Figure 6-16 Export Point Cloud

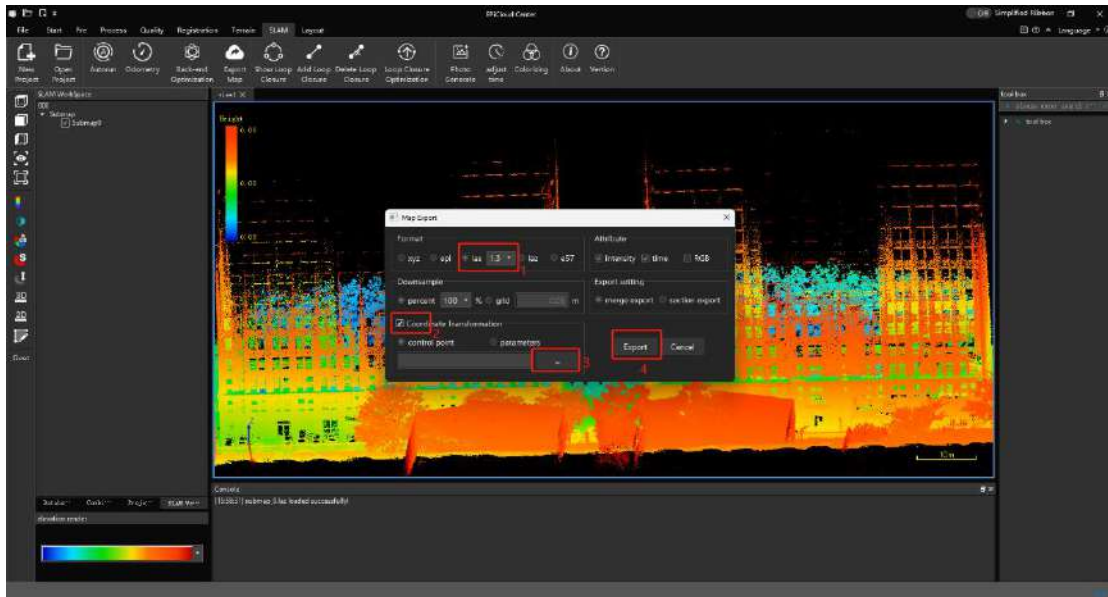

Figure 6-17 Exportation of Point Cloud

In the "Map Export" window, select the required format, check the coordinate conversion (unchecked if you don't want to convert coordinates), select the control point file "XXX.txt" in the previous step 6.4.1, and click Export to export the point cloud map with absolute coordinates. Click Export to export the point cloud with absolute coordinates.

7. Appendix

7.1. Common Trouble Shooting

7.2. Precautions for the use of equipment

In order to ensure the service life of the equipment and the accuracy of data collection, pls pay attention to the following:

- ① The equipment should be wiped down and kept clean at the beginning and end of each collection session.
- ② The unit must be removed and placed in the case for long distance transportation.
- ③ The device is not capable of work in harsh environments where there is rain, fog, haze, snow, or high temperatures.
- ④ Without supplier's consent, its not allowed to disassemble the device.
- ⑥ Pls deal with it gently when install or remove the device.
- ⑦ When the equipment is not to be used for a long period of time, place the equipment in a packing case with a desiccant inside it.